

For more free Copeland literature please visit
www.HVACRinfo.com

Copeland Scroll® Outdoor Condensing Unit



Convenience Store • Restaurant

- Medium and Low Temperature Refrigeration Applications
- R-404A
- 2 – 6 HP



The Copeland Scroll® Outdoor Condensing Unit was designed based on three factors demanded by industry users:

1

Energy Efficiency – Utilizing scroll compressor technology, variable speed fan motors, large capacity condenser coils and advanced control algorithms to optimize fan speed, energy consumption is significantly reduced. Compared to hermetic reciprocating units, end-users will save more than \$350 in annual energy costs.

2

Reliability – Combining the proven reliability of Copeland Scroll® compressors with advanced Copeland PerformanceAlert™ diagnostics, equipment reliability is greatly enhanced. Fault code alerts and fault code retrieval capabilities provide information to help improve speed and accuracy of system diagnostics. Integrated electronics provide protection against over-current, over-heating, incorrect phase rotation, compressor cycling, high pressure resets, low pressure cut-outs and liquid flood-back conditions that cause unexpected performance losses or worse, unplanned equipment failure.

3

Flexibility – The slim shape and light weight make the Copeland Scroll® Outdoor Condensing Unit aesthetically appealing and eases the installation process. The ultra quiet variable-speed fan motor significantly reduces exterior sound levels, allowing additional location flexibility. Combined with optional wall mounting capability, the Copeland Scroll Outdoor Condensing Unit delivers unmatched flexibility.

Copeland Scroll Outdoor Condensing Units are perfectly suited for walk-in cooler and freezer applications. All units integrate the many benefits of scroll compressor technology, fan speed control and Copeland PerformanceAlert™ diagnostic controls. The integration of these technologies deliver higher energy efficiency and lower sound levels, while ensuring reliable performance and operation in foodservice applications. Plus, all units feature variable-speed PSC fan motors that meet or exceed all national standards.

Standard Unit Features

- Pre-painted enclosures for corrosion protection.
- Heavy duty steel base with 1” raised legs.
- Brass service valves located externally for easy access.
- Raised electrical access panel for easier serviceability.
- Receivers with fusible plug, liquid shut-off valve and charging port.
- Easy to read moisture indicator.
- Variable-speed PSC fan motors.
- Advanced performance alert diagnostics.
- Over-sized condenser coils with additional fin corrosion protection for coastal zones.
- Light weight, slim-line profile for maneuverability and ease of installation.
- All units are factory tested for braze joint leaks, wiring connections, electrical continuity and start-up performance.



Feature

Owner/Enterprise Benefit

Energy improvement (More than \$350 per year)	<ul style="list-style-type: none"> • Lower operating costs
Sound improvement	<ul style="list-style-type: none"> • Creating a more comfortable environment for guests • Beneficial for regions with noise ordinances
Diagnostic protection capabilities	<ul style="list-style-type: none"> • Reduce cost of nuisance calls • Extends life of your equipment • Reduces potential service costs • Maintains your equipment to original standards, maintaining energy efficiency and temperature control • Have confidence in what your contractor is fixing
Slim profile, lighter weight, and optional wall mount capability	<ul style="list-style-type: none"> • Lower installation costs • Improved appearance of your enterprise site • Avoids more costly solutions for potential location issues

Medium Temperature Performance – Coolers

90°F Ambient			Capacity (Btu/hr) at Evaporator Temperature (°F)									
Model	H.P.	Compressor	-5	0	5	10	15	20	25	30	35	40
XJAM-020Z	2.0	ZX15KCE	10600	11800	13100	14600	16200	17800	19600	20800	22300	23800
XJAM-030Z	3.0	ZX21KCE	15500	17900	19300	21600	23800	26100	28500	30300	32500	34600
XJAM-040Z	4.0	ZX30KCE	21300	23900	26500	28000	32400	35500	38600	41100	44000	46900
XJAM-050Z	5.0	ZX38KCE	26700	29600	32700	35900	39400	43200	47100	49900	53300	56700
XJAM-060Z	6.0	ZX45KCE	30400	33800	37800	41800	45900	50300	54600	58300	62400	66500
95°F Ambient			Capacity (Btu/hr) at Evaporator Temperature (°F)									
Models	H.P.	Compressor	-5	0	5	10	15	20	25	30	35	40
XJAM-020Z	2.0	ZX15KCE	--	11900	12600	14000	15600	17200	18800	20100	21600	23100
XJAM-030Z	3.0	ZX21KCE	--	16800	18500	20600	22800	25000	27200	29100	31200	33300
XJAM-040Z	4.0	ZX30KCE	20400	22800	25300	27500	31000	34000	37000	39400	42200	45000
XJAM-050Z	5.0	ZX38KCE	25600	28500	31500	34600	38000	41600	45400	48200	51500	54800
XJAM-060Z	6.0	ZX45KCE	29000	32400	36100	39900	44000	48200	52400	55900	59800	63700
100°F Ambient			Capacity (Btu/hr) at Evaporator Temperature (°F)									
Models	H.P.	Compressor	-5	0	5	10	15	20	25	30	35	40
XJAM-020Z	2.0	ZX15KCE	--	10700	12000	13400	15100	16600	17900	19500	20900	22400
XJAM-030Z	3.0	ZX21KCE	--	15800	17700	19700	21700	24000	25900	27900	30000	32000
XJAM-040Z	4.0	ZX30KCE	19400	21800	24200	26900	29600	32400	35300	37700	40400	43000
XJAM-050Z	5.0	ZX38KCE	24600	27500	30300	33400	36600	40000	43800	46500	49600	52800
XJAM-060Z	6.0	ZX45KCE	27700	31000	34500	38100	42000	46000	50200	53500	57200	61000
110°F Ambient			Capacity (Btu/hr) at Evaporator Temperature (°F)									
Models	H.P.	Compressor	-5	0	5	10	15	20	25	30	35	40
XJAM-020Z	2.0	ZX15KCE	--	--	10900	12200	13600	14900	16400	17700	19100	20400
XJAM-030Z	3.0	ZX21KCE	--	--	--	17500	19900	21800	23300	25500	27400	29300
XJAM-040Z	4.0	ZX30KCE	--	--	21900	24400	26800	29500	32200	34700	37200	39800
XJAM-050Z	5.0	ZX38KCE	--	25000	27900	30700	33500	36400	39800	42500	45400	48300
XJAM-060Z	6.0	ZX45KCE	23400	27300	31400	34800	38400	42200	45900	49700	53400	57100

Low Temperature Performance – Freezers

90°F Ambient			Capacity (Btu/hr) at Evaporator Temperature (°F)								
Unit Model	H.P.	Compressor	-40	-35	-30	-25	-20	-15	-10	-5	0
XJAL-020Z	2.0	ZXI06KCE	5700	6960	8210	9450	10700	11900	13100	14400	15600
XJAL-030Z	3.0	ZXI09KCE	7840	9390	11000	12500	14100	15600	17200	18700	20300
XJAL-035Z	3.5	ZXI11KCE	9700	11100	12600	14200	15900	17700	19700	21700	23900
XJAL-040Z	4.0	ZXI14KCE	12700	14400	16300	18200	20300	22500	24700	27100	29600
XJAL-050Z	5.0	ZXI15KCE ZXI16KCE	14000	16000	18100	20400	22700	25100	27600	30200	32900
XJAL-060Z	6.0	ZXI18KCE	18000	20500	23000	25700	28600	31600	34700	38100	41500
95°F Ambient			Capacity (Btu/hr) at Evaporator Temperature (°F)								
Unit Model	H.P.	Compressor	-40	-35	-30	-25	-20	-15	-10	-5	0
XJAL-020Z	2.0	ZXI06KCE	5670	6900	8120	9330	10500	11700	12900	14100	15300
XJAL-030Z	3.0	ZXI09KCE	7390	8960	10500	12100	13700	15200	16800	18400	19900
XJAL-035Z	3.5	ZXI11KCE	9400	10700	12200	13700	15300	17000	18900	20900	22900
XJAL-040Z	4.0	ZXI14KCE	12500	14200	16000	17900	19900	22000	24200	26500	29000
XJAL-050Z	5.0	ZXI15KCE ZXI16KCE	13600	15500	17500	19700	21900	24200	26600	29100	31800
XJAL-060Z	6.0	ZXI18KCE	17500	20000	22300	25000	27600	30700	33700	37000	39900
100°F Ambient			Capacity (Btu/hr) at Evaporator Temperature (°F)								
Unit Model	H.P.	Compressor	-40	-35	-30	-25	-20	-15	-10	-5	0
XJAL-020Z	2.0	ZXI06KCE	5640	6840	8020	9200	10400	11500	12700	13800	15000
XJAL-030Z	3.0	ZXI09KCE	6940	8520	10100	11700	13300	14800	16400	18000	19600
XJAL-035Z	3.5	ZXI11KCE	9090	10300	11700	13100	14700	16300	18100	20000	21900
XJAL-040Z	4.0	ZXI14KCE	12400	14000	15700	17500	19500	21500	23700	25900	28300
XJAL-050Z	5.0	ZXI15KCE ZXI16KCE	13100	15000	16900	18900	21100	23300	25700	28100	30600
XJAL-060Z	6.0	ZXI18KCE	17200	19400	21900	24300	27000	29700	32700	35800	38200
110°F Ambient			Capacity (Btu/hr) at Evaporator Temperature (°F)								
Unit Model	H.P.	Compressor	-40	-35	-30	-25	-20	-15	-10	-5	0
XJAL-020Z	2.0	ZXI06KCE	5500	6610	7710	8810	9890	11000	12000	13100	14200
XJAL-030Z	3.0	ZXI09KCE	5830	7420	9010	10600	12200	13800	15400	16900	18500
XJAL-035Z	3.5	ZXI11KCE	9020	10100	11300	12700	14200	15700	17400	19200	21100
XJAL-040Z	4.0	ZXI14KCE	11900	13400	15000	16700	18500	20400	22400	24600	26800
XJAL-050Z	5.0	ZXI15KCE ZXI16KCE	11900	13600	15400	17300	19200	21300	23500	25700	28100
XJAL-060Z	6.0	ZXI18KCE	16200	18300	20500	22800	25100	27600	30200	32900	34700

Capacities are at 60 Hertz with 5°F subcooling, 65°F return gas. All medium temperature units are UL approved for medium temperature application (0°F - 25°F evaporator). For applications outside of this temperature range, consult your local UL representative for any additional agency requirements.

Physical and Electrical Data

Unit Model	Compressor	H.P.	Dimensions (in)			Connection Lines		# of Fans	MCA / Max Fuse (Amps)		Pump Down Capacity (lbs)	Unit Weight (lbs)
			L	W	H	Suction	Liquid		208/230V 1φ-60Hz	208/230V 3φ-60Hz		
Medium Temperature - Coolers												
XJAM-020Z	ZX15KCE	2	16.7	40.5	33	3/4 "	1/2 "	1	18.7 / 30	11.1 / 15	7.5	182
XJAM-030Z	ZX21KCE	3	16.7	40.5	33	3/4 "	1/2 "	1	24.3 / 40	14.7 / 25	7.5	194
XJAM-040Z	ZX30KCE	4	16.7	40.5	49	7/8 "	1/2 "	2	32.1 / 50	19.7 / 30	11	250
XJAM-050Z	ZX38KCE	5	16.7	40.5	49	7/8 "	1/2 "	2	36.6 / 60	29.0 / 50	11	258
XJAM-060Z	ZX45KCE	6	16.7	40.5	49	7/8 "	1/2 "	2	–	28.1 / 45	11	270
Low Temperature - Freezers												
XJAL-020Z	ZXI06KCE	2	16.7	40.5	33	3/4 "	1/2 "	1	19.4 / 30	14.7 / 25	7.5	188
XJAL-030Z	ZXI09KCE	3	16.7	40.5	33	3/4 "	1/2 "	1	–	15.4 / 25	7.5	192
XJAL-035Z	ZXI11KCE	3.5	16.7	40.5	33	7/8 "	1/2 "	1	30.7 / 50	–	7.5	213
XJAL-040Z	ZXI14KCE	4	16.7	40.5	49	7/8 "	1/2 "	2	36.1 / 60	24.5 / 40	11	251
XJAL-050Z	ZXI15KCE	5	16.7	40.5	49	7/8 "	1/2 "	2	–	26.1 / 45	11	267
XJAL-050Z	ZXI16KCE	5	16.7	40.5	49	7/8 "	1/2 "	2	40.4 / 70	–	11	287
XJAL-060Z	ZXI18KCE	6	16.7	40.5	49	7/8 "	1/2 "	2	–	30.7 / 50	11	291

Dimensional Drawings

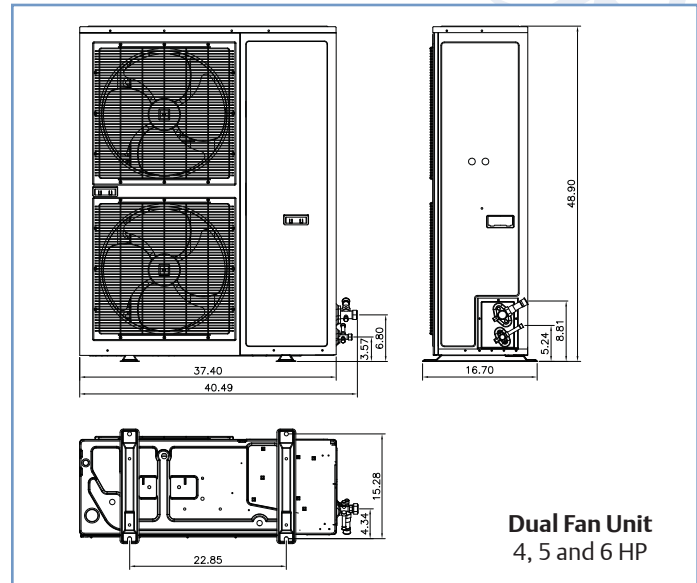
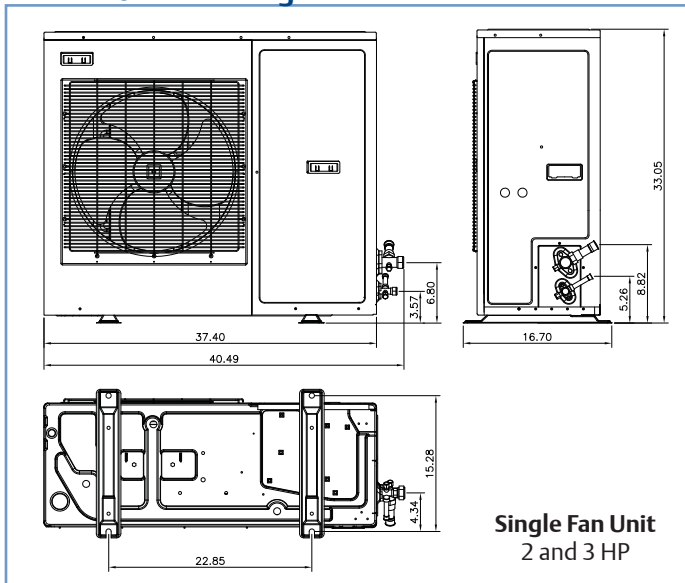

Application Engineering Bulletins

available at EmersonClimate.com

- 4-1273 *Factors to Consider in Converting Compressor Rated Capacity to Actual Capacity*
- 4-1327 *Economized Vapor Injection (EVI) Compressors*
- 11-1147 *Suction Accumulators*
- 11-1297 *Liquid Line Filter Driers*
- 17-1260 *Compressor Overheating*
- 17-1268 *Compressor Ratio as it Affects Compressor Reliability*
- 22-1182 *Liquid Refrigerant Control in Refrigeration and Air Conditioning Systems*

2009IP-43 Copeland Scroll Outdoor Condensing Unit Installation and Reference Manual is provided with each unit and is a source for additional product details.

2007IP-52 Refrigeration Load Calculator software is available to compute refrigeration loads and select matching components. Contact your Emerson sales manager for more details.

For more information about Copeland Scroll Outdoor Condensing Units, please visit: EmersonClimate.com/copelandoutdoorunit

Nomenclature

X	J	A	M	-	0	2	0	Z	-	T	F	C	-	0	0	2
Family = X-Line	J = R-404A	A = Air-Cooled	M = Medium Temp L = Low Temp					2.0 to 6.0 = H.P.		Z = Scroll		CFV = 208/230V-1ph-60Hz TFC = 208/230V-3ph-60Hz		0 = UL Listed Product		02 = Standard

To place an order select **Base Model** > **Electrical** > **Bill of Material***

*The XJ Series is only available in the featured -002 Bill of Material.