



**Application Engineering Bulletin
AE-1265-R4**

Revised December, 1994

MODEL 8D COMPRESSORS

The model 8D compressor family reflects the growing importance of Copeland's world wide activities. The basic development engineering was done by Copeland's European division, in close cooperation with Copeland's Sidney, Ohio engineering group.

8D Family

The initial 8D models are the 8DP1-5000 and the 8DS1-6000. The 8DP1 is an 8 cylinder version of the 6D-35 H.P. family with common valve plates, pistons, and rods. The 8DS1 is an 8 cylinder version of the 6D-40 H.P. family with common valve plates, pistons, and rods.

Both 8D models are made with two unloaded cylinder banks, so the basic model nomenclature follows the 6D models, i.e. 8DP and 6DP, 8DS and 6DS. The 8D models are furnished with pads over the standard Copeland internal unloader mechanism so they may be operated fully loaded as received with the pads installed. There is no model distinction between a standard and unloaded version. If unloading is desired, then solenoid kits are available on a special bill of material and may be installed on one or both cylinder banks as desired.

In a similar fashion, all compressors are shipped with pads over the valve openings, less solid state module, and the proper bill of material will identify the valves and solid state module which will be shipped as accessory parts.

Electrical Characteristics

The 6D compressors are available in two electrical versions.

TSK models will have 9 lead motors, and can be connected for 208/230-3-60 power part winding or across the line.

FSD models will have 6 lead motors and may be connected for 460-3-60 and 380/400-3-50 power either part winding or across the line, or may be connected for 460-3-60 and 400-3-50 across the line.

The protection system is the standard T.I. solid state motor protection used on all 4D and 6D compressors.

On a two contractor installation each contractor must be sized adequately to carry the locked rotor current. Since the contractor is an integral part of the protection system, proper contractor application is a requirement of the Copeland warranty.

Application

8D compressors are presently released for R-22 high temperature applications with unloading and for R-502 medium temperature applications fully loaded only. These compressors are not approved for low temperature applications and should not be applied outside their published operating parameters.

Because of the internal design of the motor, there is a much higher pressure drop across the motor of an operating compressor than typically seen on other Copeland compressors. This can complicate oil equalization problems on parallel applications. A float oil equalization system is therefore recommended if parallel application is desired.

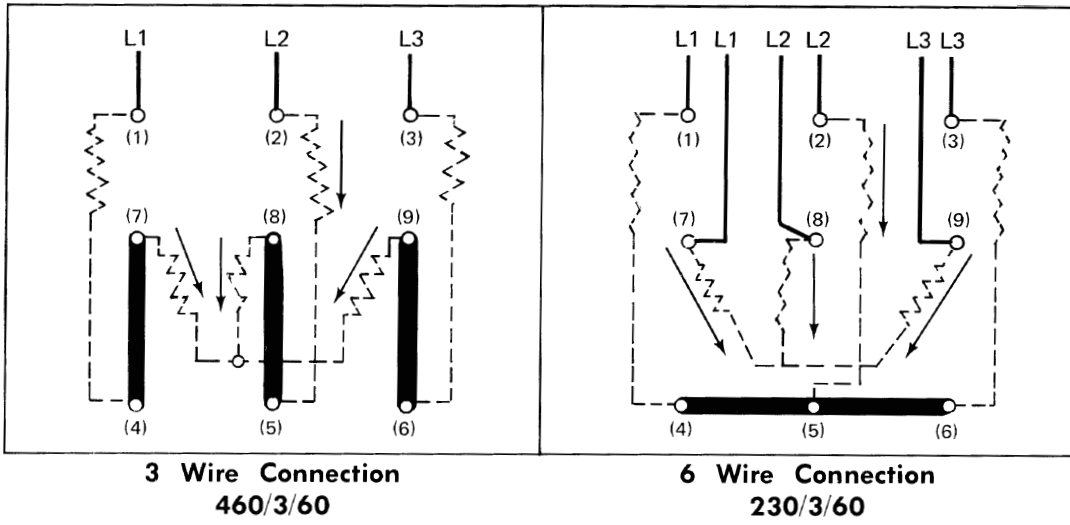

TSK Wiring Connections

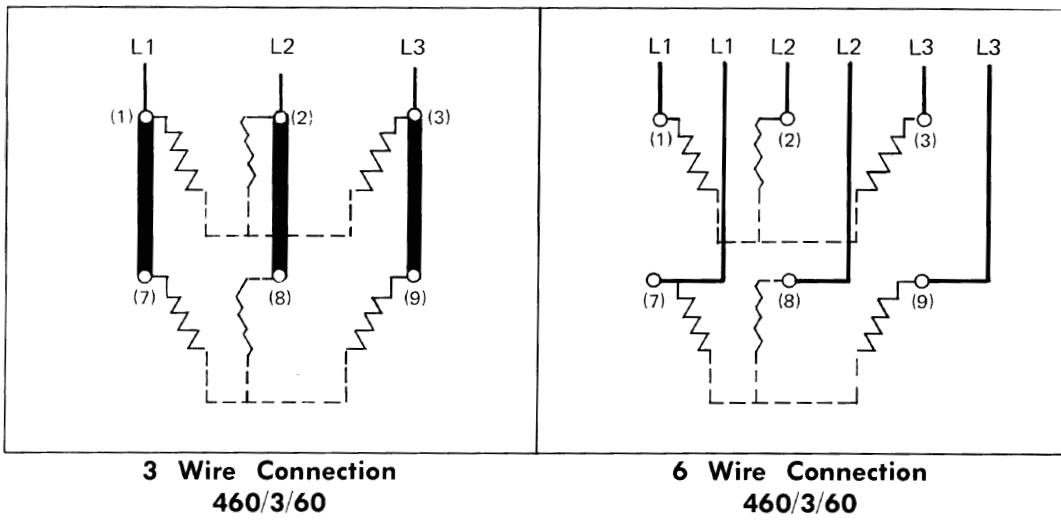

FSD Wiring Connections

MODEL 8D COMPRESSOR LINE

MODEL	8DP1-5000-TSK	8DP1-5000-FSD	8DS1-6000-TSK	8DS1-6000-FSD
60 HZ. Displacement R-22 Capacity, ARI	6428 CFH 566,000 BTU/HR	6428 CFH 566,000 BTU/HR	7608 CFH 650,000 BTU/HR	7608 CFH 650,000 BTU/HR
Voltage Rating	208/230-3-60 ACL 208/230-3-60 PWS 460/3/60 ACL 400/3/50 ACL	460-3-60 ACL 460-3-60 PWS 380/400-3-50 ACL 380/400-3-50 PWS	208/230-3-60 ACL 208/230-3-60 PWS 460-3-60 ACL 400-3-50 ACL	460-3-60 ACL 460-3-60 PWS 380/400-3-50 ACL 380/400-3-50 PWS
230 Volt LRA, ACL LRA, Part Wdg. MCC RLA	1070 Amps 654 Amps 252 Amps 180 Amps	— — — —	1070 Amps 654 Amps 314 Amps 224 Amps	— — — —
460 Volt LRA, ACL LRA, Part Wdg. MCC RLA	535 Amps — 126 Amps 90 Amps	510 Amps 330 Amps 127 Amps 91 Amps	535 Amps — 157 Amps 112 Amps	510 Amps 330 Amps 135 Amps 96.5 Amps
Contactor Sizing 208/230 V. 2 Contactor 460 V. 1 Contactor 460 V. 2 Contactor	2 - 120 Amp* 120 Amps —	— 120 Amps 2 - 90 Amp*	2 - 120 Amp* 120 Amps —	— 120 Amps 2 - 90 Amps*

*Must be U.L. approved for part winding applications at 100% of ACL LRA rating.

